



1310nm indoor Optical Relay Station

OP-OTDM131



Shenzhen Optostar Optoelectronics Co., Ltd

2016. 3 (Version 2)

1. Summary

OP-OTDM131 series of 1310nm optical relay station is a special product with HFC network engineering experience and equipment development experience accumulate for many years by ourselves only for 1310nm optical relay transmission. An economical and practical solution is provided by 1310nm optical relay transmission in CATV engineering practice.

2. Performance Characteristics

- PHILIPS or E-O high-sensitivity PIN optical detector is used in the part of optical receiving, and high performance DFB laser with international famous brands are used in the part of optical transmitter.
- PHILIPS, PHOTON or E-O high-sensitivity PIN optical detector are used in the part of optical receiving; High performance DFB laser with international famous brands are used in the part of optical transmitter, what we do is to ensure the excellent performance index of the whole machine.
- The technical performance parameters in the part of optical transmitter are the same as WT Series Optical Transmitter; The technical performance parameters in the part of optical receiving are the same as WR Series Optical Transmitter. And the high-quality RF signal is exported to cover the local user.
- Internal RF signal is automatic process, and it 's easy to use; The process structure is tight and reasonable. The installation and adjustment are convenient. The performance is stable and reliable.
- Blue VFD display is built in 19 "1U high-standard rack, and Indoor (II)-type machine is the 19 "1U high-standard rack.
- High-power electric cooler is built in the field (III)-type machine to make the difference in temperature of operating environment to meet $\pm 40^{\circ}\text{C}$. Large cast aluminum waterproof housing, high-performance switch power and strict anti-lightning system are adopted to ensure the equipment can work steadily in the field harsh environment for a long time.

3. Block Diagram

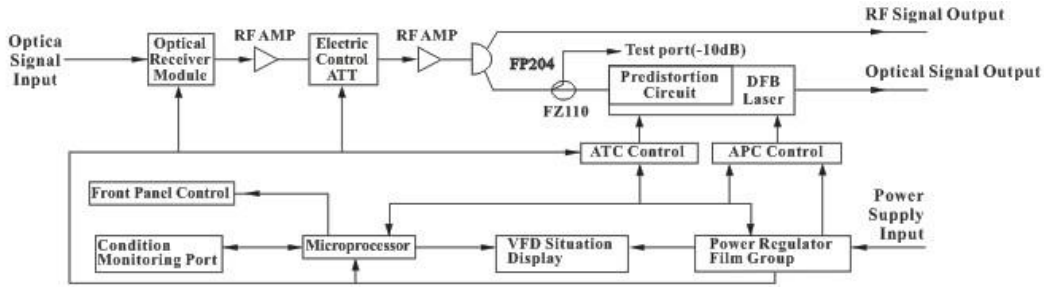

WT8600II, WT7500 II Series 1310nm Indoor Laser Transmitter Block Diagram

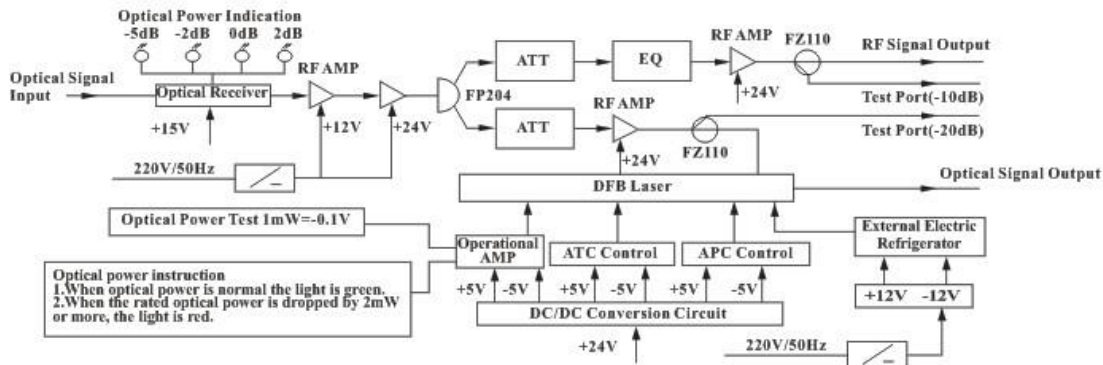

WT8600II, WT7500 II Series 1310nm Outdoor Laser Transmitter Block Diagram

4. Technique Parameters

Items	Unit	Technique Parameters									
		4	6	8	10	12	14	16	18	20	22
Output Optical Power	mW	4	6	8	10	12	14	16	18	20	22
Optical Link Loss	dB	7	9	10	11	11.8	12.5	13	13.6	14	14.4
Optical Wavelength	nm	1310±20									
Laser Type		DFB Laser									
Optical Modulating Mode		Directly Optical Intension Modulation									
Optical Connector Type		FC/APC OR SC/APC									
Frequency Range	MHz	47~750/862									
Input Level	dBμV	72~88									
Flatness in Band	dB	±0.75									
Input Impedance	Ω	75									
Input Return Loss	dB	≥ 16 (47~550) MHz; ≥ 14 (550~750/862MHz)									
C/CTB	dB	≥ 65									
C/CSO	dB	≥ 60									
C/N	dB	≥ 51									
AGC Controlled Range	dB	±8									
MGC Controlled Range	dB	±8									
Supply Voltage	V	AC 160V~250V (50 Hz)									

Consumption	W	30
Operating Temperature	°C	-5~+55
Storage Temperature	°C	-20 ~+65
Relative Humidity	%	Max 95%No Condensation
Dimension	mm	483 (L) X 380 (W) X 44 (H)

5. Ordering Guide

1. Please check the optical interface of the equipment when ordering. The defaulted interface is FC/APC interface. If you have other special requirements, please tell us when ordering.
2. When customer some special requirement on key components such as lasers, please tell us when ordering.
3. There are AC60V and AC220V as power supply of wild model, so please tell us when ordering.